

FEATURES

- Stain-resistant vitreous china
- Elongated front bowl
- High efficiency-consumption 1.6 gpf/6.0 Lpf & 1.0 gpf/4.2 Lpf
- Choose either 1.6 or 1.0 gpf. Push back for full 1.6 gpf; pull forward for reduced 1.0 gpf*
- 12" (305 mm) rough-in
- Wide 2" (51 mm) trapway
- Brushed metal look tank trip lever
- 20 - 1/2" x 10" footprint
- Sanitary bar on bowl for easy cleaning
- Toilet seat sold separately
- Limited lifetime warranty

*Estimated average consumption at or below 1.28 gpf based on HET standard of 2 reduced flushes for each full flush

MODEL & DESCRIPTION

Combination 4212 consists of:

4370 Conserver elongated front bowl
Shipping weight: 43 lb (20 kg)

4488 Conserver tank
Shipping weight: 27 lb (12 kg)

Tank Lid:

7488 Tank Lid for 4488

CODES & STANDARDS

Meets or exceeds the following:

- ASME A112.19.2
- IAPMO/cUPC
- HET (High Efficiency Toilet)
- EPA WaterSense



COLORS

- WHITE (130)

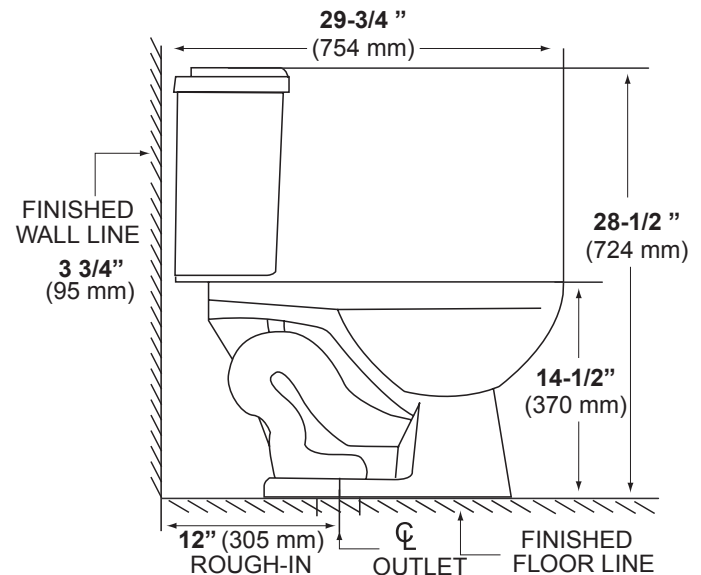
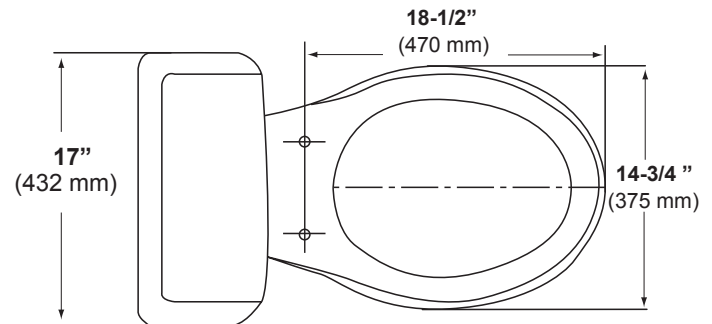

Dimensions may vary (+) or (-) 1/4". Dimensions shown in parentheses are in millimeters: 25.4 mm = 1 inch. Note: Fixture dimensions are nominal and conform with dimension and performance requirements of ASME A112.19.2-2008/CSA B45.1-08 standards. PSI rating: 20 minimum to 80 maximum per ASME A112.19.2-2008/CSA B45.1-08 standards. Dimensions subject to change or cancellation without notice. Briggs is not responsible for the use of superseded or voided specification information.

stcontle1012

BRIGGS®

(800) 888-4458
www.briggsplumbing.com